

**For your safety, please read the following before using.**

- Do not use corrosive or flammable gas or liquid with this product.
- Please use within the operating pressure range. Do not apply pressure beyond recommended maximum pressure, permanent damage to the pressure sensor may occur.
- Do not drop, hit or allow excessive shock (1000m/s<sup>2</sup> or 100G). Even if switch body appears undamaged, internal components may be broken and can cause malfunction.
- Turn power off before connecting wiring. Wrong wiring or short circuit will damage and / or cause malfunction.
- Do not use in environment containing steam or oil vapor.
- This product is not explosion-proof rated. Do not use in atmosphere containing flammable or explosive gases.
- Wiring for pressure sensor should avoid power source line and high voltage line. If use in the same circuit, noise may cause malfunction.

**ORDER NO.**

**V17-PC**



**① Pressure range**

V17 - Vacuum Pressure (-101.3 ~ 0 kPa)

**② Output type**

P - PNP output

No mark - NPN output

**③ Analog out put & Cable specification**

C - M8, 4Pin connector

G - 4-Core 2m lead wire

GA-5-Core 2m lead wire with Analog output

**M8-Female Connector**

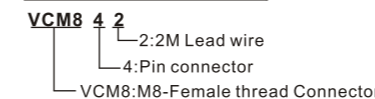

**MODEL:VCM8 42**

- (1) Brown
- (2) White
- (3) Blue
- (4) Black

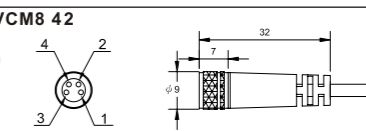

SPECIFICATIONS		V17-□ (Vacuum)
Rated pressure range		-101.3~0.0kPa
Operating /Setting pressure range		-101.3~10.0 kPa
Withstand pressure		3 times of rated pressure range
Fluid		Air, Non-corrosive gases ,incombustible gases
Set pressure resolution	kPa	0.1
	MPa	—
	kgf/cm <sup>2</sup>	0.001
	bar	0.001
	psi	0.01
	InHg	0.1
	mmHg	1
	mmH <sub>2</sub> O	0.1
Power supply voltage		12 to 24VDC ±10%, Ripple (P-P) 10% or less
Current consumption		≤55mA
Switch output		NPN:open collector 2 outputs Max. load current : 80mA Max. supply voltage: 30VDC Residual voltage : ≤1V (load current 80mA) PNP:open collector 2 outputs Max. load current : 80mA Max. supply voltage: 24VDC Residual voltage : ≤1V (load current 80mA)
Repeatability(Switch output)		≤±0.2% F.S. ±1digit
Hysteresis	Hysteresis mode	Adjustable
	Window comparator mode	Fixed(3 digits)
Response time		≤2. 5ms (chattering-proof function: 24ms, 192ms and 768ms selections)
Output short circuit protection		Yes
7 segment LED display		3 1/2 digit LED 7 segment display (Sampling rate: 5 times/1sec.)
Indicator accuracy		≤±2% F.S. ±1 digit (ambient temperature: 25 ±3°C)
Indicator		Green LED (OUT1) Red LED (OUT2)
Analog output *(Only type V17-PGA, V17-GA)		Output voltage: 1 to 5V ≤±2.5%F.S. (within rated pressure range) Linearity: ≤±1% F.S.
Environment	Enclosure	IP40
	Ambient temp. range	Operation: 0 ~ 50°C, Storage:-20 ~ 60°C ( No condensation or freezing)
	Ambient humidity range	Operation/Storage: 35 ~ 85% RH ( No condensation)
	Withstand voltage	1000VAC in 1-min (between case and lead wire)
	Insulation resistance	50Mohm min. (at 500VDC M, between case and lead wire)
	Vibration	Total amplitude 1.5mm,10Hz-55Hz-10Hz scan for 1 minute, two hours each direction of X,Y and Z
	Shock	980m/s <sup>2</sup> (100G),3 times each in direction of X,Y and Z
Temperature characteristic		≤±2% F.S. of detected pressure (25°C) at temp. Range of 0~50°C
Lead wire		Oil-resistance cable(0.15mm <sup>2</sup> )
Weight		Appro*67g(with 2-meter lead wire),Appro*35g(with male connector )

**OUTPUT CIRCUIT WIRING GRAPH**

**V17 - GA  
NPN output**

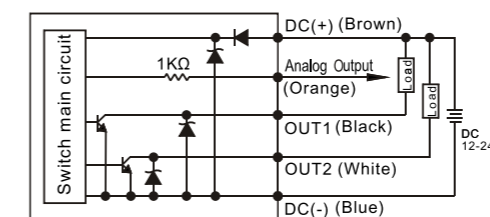

**V17 - C/G  
NPN output**

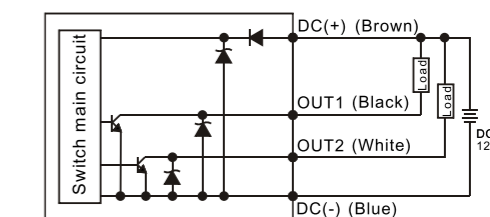

**V17- PGA  
PNP output**

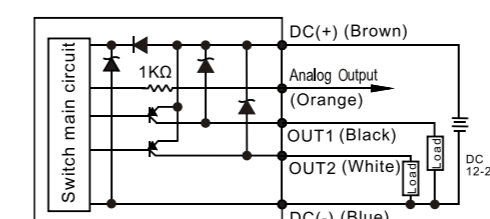

**V17- PC/PG  
PNP output**

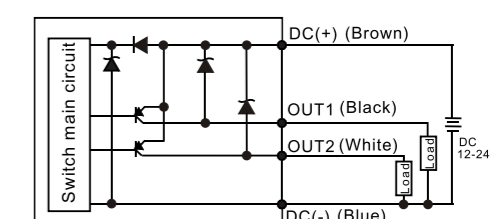

**DIMENSION GRAPH**

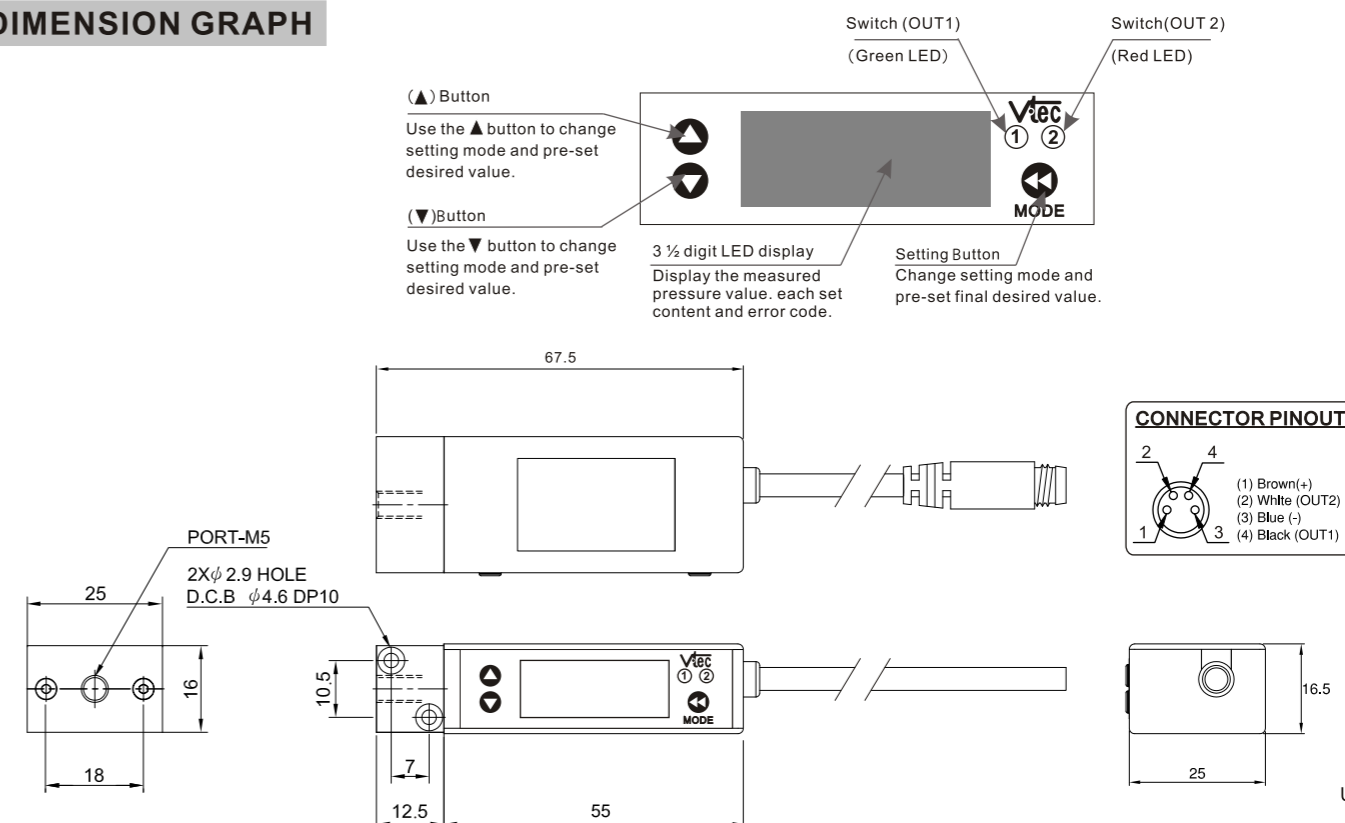

## CHANGE PRESSURE UNIT TAG

When the pressure setting is not **kPa**, please remove the pressure unit tag and place the selected tag on the indicated area of the faceplate to assure the pressure unit is not misemployed and that setting error does not occur.

From	To	Pa	kPa	MPa	kgf/cm <sup>2</sup>	mmHg	psi	bar	inHg	mmH <sub>2</sub> O
1 Pa	1	0.001	0.000001	0.000010197	0.00750062	0.000145038	0.00001	0.0002593	0.101968	
1 kPa	1000.000	1	0.001000	0.010197	7.500616	0.145038	0.010000	0.2953	101.9689	
1 MPa	1000000	1000	1	10.197	7500.616	145.038	10	295.2998	101968.9	
1 kgf/cm <sup>2</sup>	98066.5	98.0665	0.0980665	1	735.559	14.2233	0.980665	28.95979	10000.20	
1 mmHg	133.32	0.13332	0.000133	0.0013595	1	0.019336	0.0013332	0.039370	13.5954	
1 psi	6895	6.895	0.006895	0.07031	51.7157	1	0.06895	2.036074	703.07	
1 bar	100000.0	100.0000	0.100000	1.01972	750.062	14.5038	1	29.52998	10196.89	
1 inHg	3386.388	3.386388	0.003386	0.034530	25.40000	0.491141	0.033863	1	345.324	
1 mmH <sub>2</sub> O	9.80665	0.00980	-	0.000099	0.0735578	0.00142	0.000098	0.002895	1	

[ Note : ] When using a unit mmH<sub>2</sub>O, please multiply display value by 100.

## SETTING STEPS

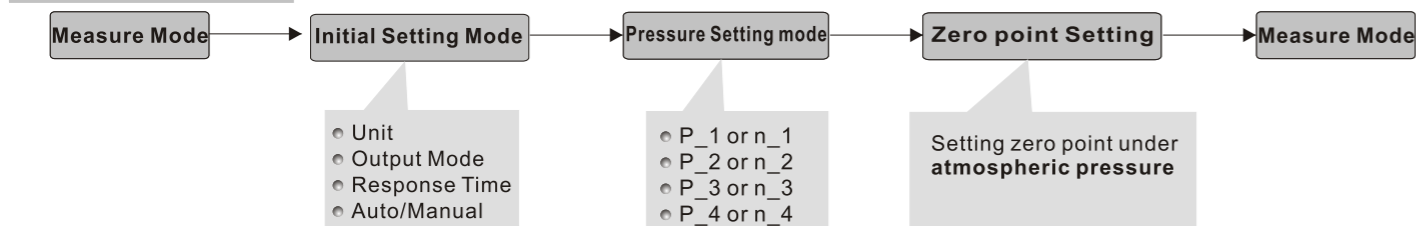

## INITIAL SETTING MODE

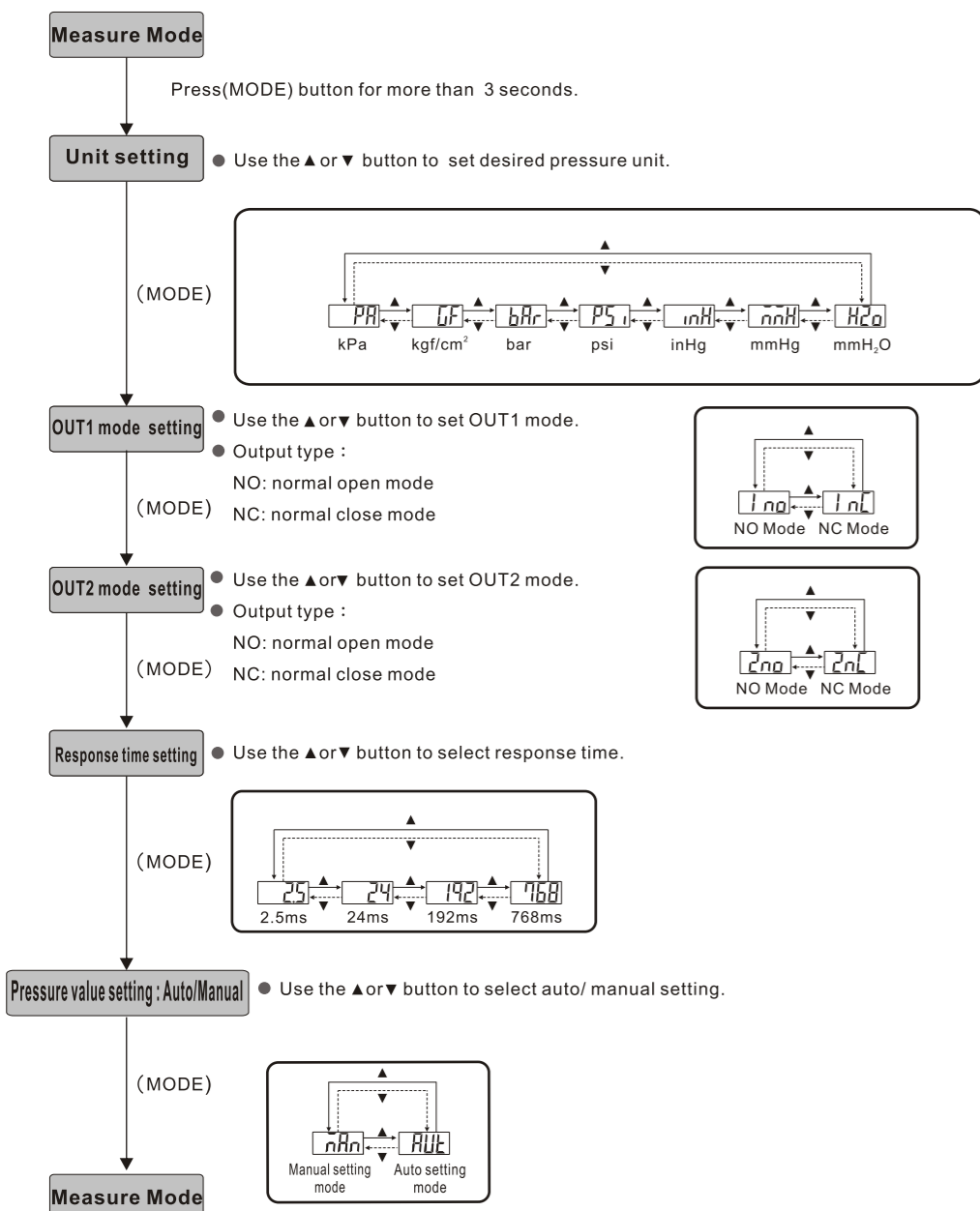

## PRESSURE SETTING MODE

Select auto/manual setting mode during initial set-up

### Manual setting mode

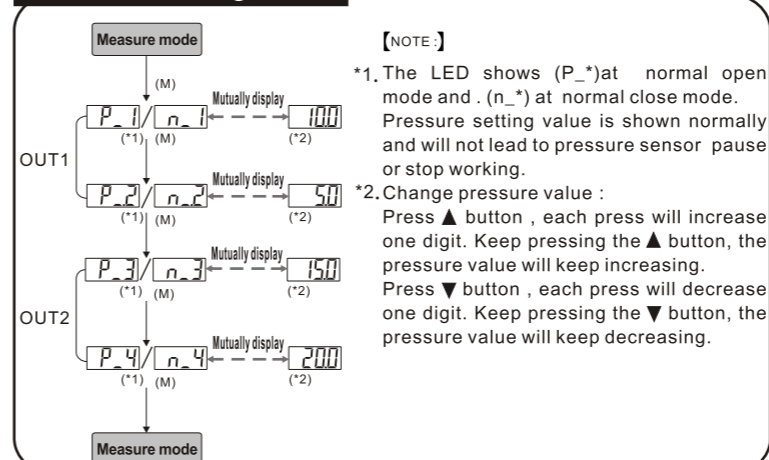

### Auto setting mode

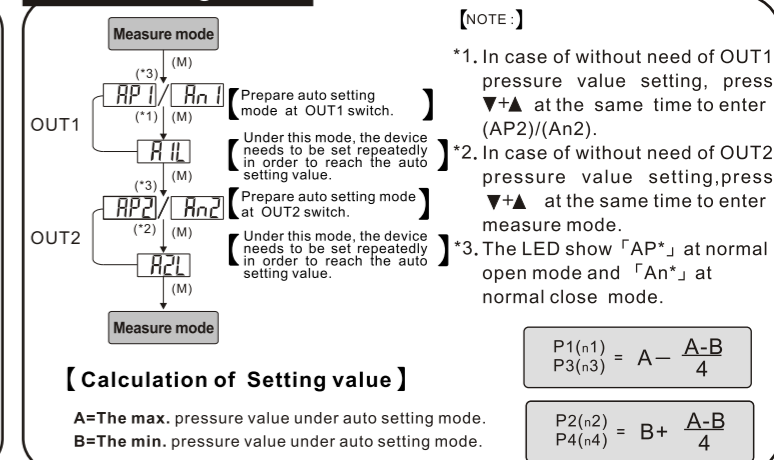

## OUTPUT TYPE

**Hysteresis Mode :** P1(n1) > P2(n2), P3(n3) > P4(n4)

Output hysteresis value can be pre-set.

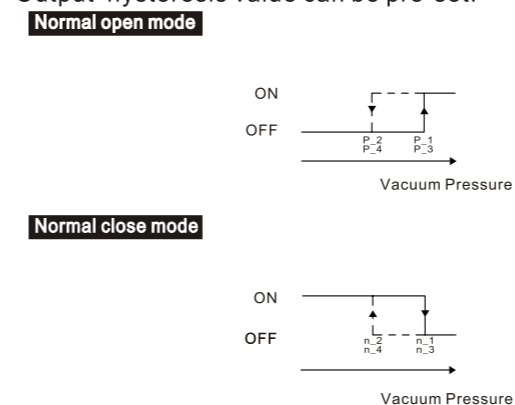

[ Note : ] When hysteresis mode setting is within 2 digits, if the input and pre-set pressure is quite near, pressure sensor output might cause chattering.

**Window comparator mode :** P1(n1) < P2(n2), P3(n3) < P4(n4)

Within pressure setting range, pressure sensor output can be ON or OFF.

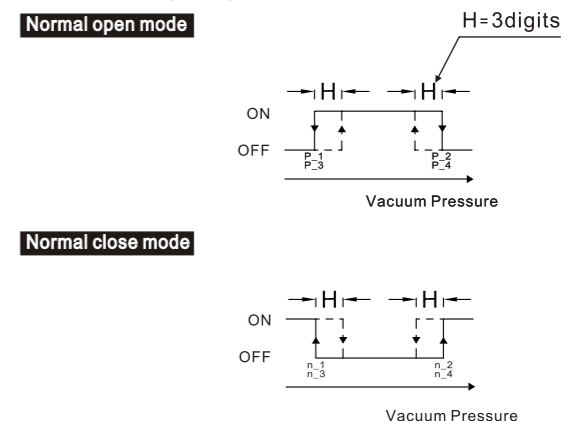

Note : Hysteresis is fixed in 3 digits.  
Pressure value level setting : At least 6 digits.

## ZERO POINT SETTING / THE MAX. & MIN. DISPLAY MODE

**Zero setting :**

- Press the ▼+▲ button at the same time until the "00" is shown. Release the button to end zero setting.

**The Max. value display mode :**

- Press ▲ button 2 seconds to enter the max. value mode, pressure sensor will detect the max. value and keep display.
- Press ▲ button 2 seconds to return to measure mode.

**The Min. value display mode :**

- Press ▼ button 2 seconds to enter the min. value mode, pressure sensor will detect the min. value and keep display.
- Press ▼ button 2 seconds to return to measure mode.

## KEY LOCK/UNLOCK MODE

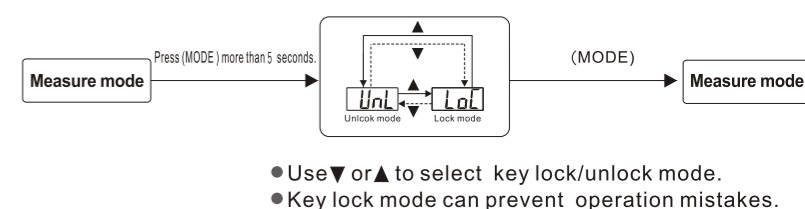

## ERROR CODE INSTRUCTION

Error Name	Error code	Error instruction	Troubleshooting
Excess load current error	OUT1 Er1	Excess load current of 80 mA	Turn power off and check the cause of overload current or lower the current load under 80 mA, then restart.
	OUT2 Er2		
Residual pressure error	Er3	During zero reset, ambient pressure is over ±3.0kPa for vacuum pressure.	Change input pressure to ambient pressure and perform zero reset again.
Applied pressure error	---	The applied pressure is excess the upper limit of pressure setting.	Adjust the pressure within applied pressure range.
	---	The applied pressure is excess the lower limit of pressure setting.	
System error	Er4	Internal data error	Turn power off, and then restart. If error condition remains, please return to factory for inspection.
	Er6	Internal system error	
	Er7	Internal data error	
	Er8	Internal system error	